

Experiment No: 15

PRECISION RECTIFIER USING OP-AMP

AIM

To design and set up precision rectifier using op-amp and check its performance.

EQUIPMENT AND COMPONENTS REQUIRED

Dual power supply, CRO, function generator, bread board, op-amp, diodes, and resistors.

THEORY

In a normal diode rectifier, the cut in voltage across the diode will result in reduction of output voltage and inaccuracy of rectification. If ideal rectifier is needed in an application, a precision rectifier as shown Fig. 1 may be used.

In the circuit, when the input is greater than zero, D_1 will conduct and D_2 is OFF, so the output is zero because the other end of R_2 is connected to the virtual ground and there is no current through R_2 . When the input is less than zero, D_2 is on, and D_1 is off, and the output is

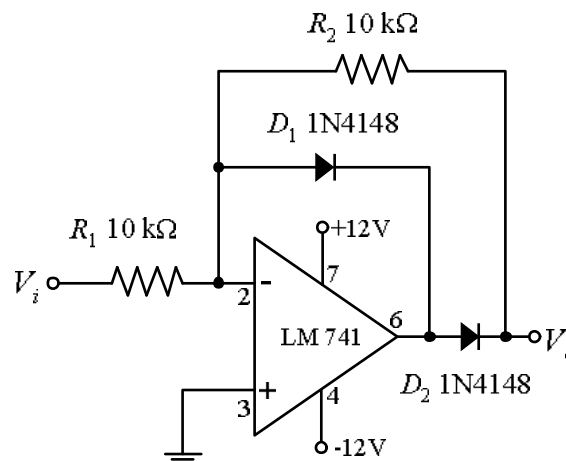

Fig 1. Circuit diagram of Precision Rectifier

similar to that of an inverting amplifier with gain $-\frac{R_2}{R_1}$.

The value of R_1 and R_2 are selected in such a way that the circuit has reasonable level of input impedance and the gain is unity. Diode D_1 and D_2 are signal diodes.

PROCEDURE

1. Set up the circuit as shown in figure. Give a sine wave of $\pm 5V$ peak magnitude and 1 kHz frequency at the input and observe the input and output simultaneously on CRO.
2. Put the CRO into X-Y mode and connect input signal to X and output signal to Y. Select suitable volt per division in both channels and observe the characteristics. The display should look similar to Fig 3.

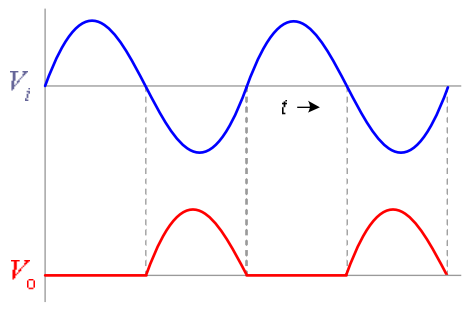

Fig. 2. Input and output waveforms

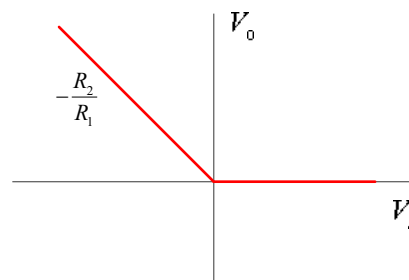

Fig. 3. Transfer characteristics